

5-2017

GROWTH PATTERNS AND SIZE-GROUP INTERACTIONS IN HATCHERY-REARED AGE-0 LAKE STURGEON

Joseph M. Susco
Northern Michigan University, jsusco@nmu.edu

Follow this and additional works at: <https://commons.nmu.edu/theses>



Part of the [Aquaculture and Fisheries Commons](#), and the [Other Physiology Commons](#)

Recommended Citation

Susco, Joseph M., "GROWTH PATTERNS AND SIZE-GROUP INTERACTIONS IN HATCHERY-REARED AGE-0 LAKE STURGEON" (2017). *All NMU Master's Theses*. 138.
<https://commons.nmu.edu/theses/138>

This Open Access is brought to you for free and open access by the Student Works at NMU Commons. It has been accepted for inclusion in All NMU Master's Theses by an authorized administrator of NMU Commons. For more information, please contact kmcdonou@nmu.edu, bsarjean@nmu.edu.

GROWTH PATTERNS AND SIZE-GROUP INTERACTIONS IN HATCHERY-
REARED AGE-0 LAKE STURGEON

by

Joseph M. Susco

THESIS

Submitted to Northern Michigan University in partial fulfillment of the requirements for
the degree of

MASTER OF SCIENCE

Office of Graduate Education and Research

2017

SIGNATURE APPROVAL PAGE

This thesis by Joseph M. Susco is recommended for approval by the student's thesis committee in the Department of Biology and the Assistant Provost for Graduate Education and Research.

Committee Chair: Dr. Jill B.K. Leonard Date

First Reader: Dr. Edward Baker Date

Second Reader: Dr. John Bruggink Date

Third Reader: Dr. Erich Ottem Date

Department Head: Dr. John Rebers Date

Interim Director of Graduate Education: Dr. Lisa Eckert Date

ABSTRACT

GROWTH PATTERNS AND SIZE-GROUP INTERACTIONS IN HATCHERY-REARED AGE-0 LAKE STURGEON

by

Joseph M. Susco

Raising lake sturgeon (*Acipenser fulvescens*) in hatcheries is an important tool for rehabilitation and conservation, but is expensive. When hatchery sturgeon do not grow large enough before stocking, their odds of survival decline significantly and resources are wasted. We investigated the potential limiting effect of large lake sturgeon on the growth rate of smaller conspecifics housed in the same tank, and the possibility of increasing growth rates by separating individuals into different size classes. We also examined plasma cortisol levels of the different size classes over time as an indicator of stress levels, and levels of free plasma thyroid hormones triiodothyronine (T₃) and thyroxine (T₄). A single family of lake sturgeon (one male/female cross) was raised in the Northern Michigan University Aquatics laboratory for one year. Growth of the sturgeon was determined both as group averages and for individuals. Separating lake sturgeon by size group had no discernable effect on average growth rates in any of the size categories, but individuals within size groups did show increased growth rates. All three categories ended the experiment with broadened size distributions. Cortisol levels showed no consistent differences based on size (Cortisol [pg/mL ± SE] = 229.27 ± 11.21). Plasma thyroid hormone levels were also similar between size categories (T₃ [pg/mL ± SE] = 8.53 ± 0.26; T₄ = 0.86 ± 0.04). Separation of lake sturgeon by size category does not appear to increase their average growth rates in captivity, but all size groups continued to increase in size throughout the experiment.

Copyright by

Joseph M. Susco

2017

ACKNOWLEDGMENTS

I thank my advisor, Dr. Jill Leonard, for her vital guidance throughout the project in procedure design, hormone assays, statistical analysis, and writing. I also greatly appreciate her assistance in obtaining funding and licensing for working with a species of concern in the state of Michigan. I also thank Dr. Edward Baker for valuable advice on sturgeon biology, aquaculture training, and for helping me gain access to lake sturgeon eggs for the study. I also thank Drs. John Bruggink and Erich Ottem for their input and insight.

I thank the Northern Michigan University Aquatics crew for their assistance in the care of experimental fish during the study, as well as occasionally helping with the often monumental task of keeping the tank systems clean and the fish alive. I also thank the members of the NMU Aquatics lab and other volunteers who assisted in the collection of data throughout the experiment. Special thanks to Spenser Chicoine for training and helping me work through the hormone assay kits when they finally came in.

I also thank the State of Michigan Department of Natural Resources for allowing the collection of sturgeon eggs at the Black River sturgeon hatching facility, as well as providing a location at Otsego Lake for juvenile release after completion of the study.

Funding was provided by the NMU Excellence in Education Award, Fred Waara Chapter Trout Unlimited Fellowship Grant, NMU Biology Department Development Fund, and the Leonard Lab Fund.

This thesis was written in the format used by *Transactions of the American Fisheries Society*.

TABLE OF CONTENTS

LIST OF FIGURES v

CHAPTER 1: LITERATURE REVIEW 1

Lake Sturgeon Biology 1

History of Sturgeon in the Great Lakes 3

Stress and Endocrine Growth Control 4

Growth Compensation 7

CHAPTER 2: GROWTH PATTERNS AND SIZE-GROUP
INTERACTIONS IN HATCHERY-REARED AGE-0 LAKE
STURGEON 9

Introduction 9

Methods 11

Results 15

Discussion 17

REFERENCES 34

APPENDIX A: IACUC APPROVAL 42

LIST OF TABLES

Table 1: Abundance, biomass, and densities of sturgeon in all tanks at time of separation into size groups (107 days post-hatch) and the end of the experiment (191 days post-hatch)..... 24

LIST OF FIGURES

Figure 1: Experiment timeline from egg fertilization to release of remaining sturgeon 25

Figure 2: Recirculating tank systems, including filters (filtered water flow shown as light arrows, waste water as dark arrows) 26

Figure 3: Mean total lengths of sturgeon in each size group (Small:●, Medium:○, Large:▼)from tank system 1 (a) and system 2 (b) and mean weights of sturgeon from system 1 (c) and system 2 (d) with standard errors represented by error bars 27

Figure 4: Total length-frequency distributions of sturgeon in Small (a, d), Medium (b, e) and Large (c, f) size groups at time of separation (a, b, c) and the end of the experimental period (d, e, f) 28

Figure 5: Length-frequency distributions of sturgeon from all three size groups superimposed to show overlap (Small: yellow, Medium: dark blue, Large: light blue) 29

Figure 6: Change in total length of tagged individuals in Small (a), Medium (b), and Large (c) size groups over time from separation to the end of the experimental period 30

Figure 7: Plot of instantaneous growth versus initial length of tagged sturgeon from each size group (Small: ●, Medium: ○, Large: ▼) from time of separation until the conclusion of the experiment 31

Figure 8: Mean plasma cortisol concentration (pg/mL) of sturgeon in each size group (Small:●, Medium:○, Large:▼) over the course of the experiment with standard errors represented by error bars 32

Figure 9: Mean plasma concentrations of T₃ (a) and T₄ (b) of sturgeon from all three size groups with standard errors shown as error bars 33

CHAPTER 1: LITERATURE REVIEW

Sturgeons (Acipenseridae) are distributed throughout North America and Eurasia in temperate and sub-Arctic regions (Bemis and Kynard 1994). Lake sturgeon (*Acipenser fulvescens*) are the only sturgeon species native to the Great Lakes and Hudson Bay regions, and one of several sturgeons endemic to the Mississippi River system. They are the largest and longest-lived fish in their range, and are characterized by large body size, a flattened rostrum, sensory barbels, bony scutes, and a heterocercal tail. Like all sturgeons, their morphology has remained highly conserved and closely resembles that of *Asiacipenser kotelnikovi*, the earliest-known fossil sturgeon dating from the Jurassic Period (Nesov et al. 1990). Unlike coelocanths and other so-called “living fossil” fish, sturgeon are notably speciose, including four genera and 27 species worldwide (Bemis and Kynard 1994). When lake sturgeon evolved as a distinct species is not certain, although mitochondrial DNA analysis shows the greatest similarity between lake sturgeon and shortnose sturgeon (*A. brevirostrum*), as well as the two Pacific North American species (*A. transmontanus* and *A. medirostris*) (Krieger et al. 2000). A high degree of genetic stock structure within the species range has been attributed to the substantial fidelity displayed by sturgeon toward their natal stream, in combination with isolation by glaciation into three distinct refugia followed by recolonization after the glaciers receded. Analysis of mitochondrial DNA reveals significant divergence among sturgeon in the Hudson Bay, upper Mississippi, and Great Lakes drainages, all of which may be subdivided further by microsatellite data into local spawning populations (Welsh 2013).

LAKE STURGEON BIOLOGY

All sturgeon migrate to their natal stream to spawn. Different species may be either anadromous or potadromous, spending their adult lives in either saltwater or large bodies of freshwater, respectively (Bemis and Kynard 1994), although anadromous species have occasionally been found maturing and reproducing entirely in freshwater systems (Paragamian et al. 2011; Gesner et al. 2014). Lake sturgeon are an entirely freshwater species and will either migrate upriver from large lakes or from lower reaches of a river system during late spring and early summer when water temperatures are between 12-18°C. The adults congregate above coarse gravel or cobble in moderately fast current >0.91 m/s, where males stimulate females to release their eggs by beating against her sides with their tails before broadcasting milt (Threader et al. 1998). Fertilized eggs become negatively buoyant and highly adhesive, allowing them to sink into spaces between the bottom substrate and adhere in place until hatching, which typically takes place approximately 5 days after spawning. Adult sturgeon exhibit no parental care, and depart downstream following spawning (Baker and Auer 2013). Juvenile sturgeon remain in their natal stream for their first year of life, and during this period experience high mortality rates. It is estimated that 91% of eggs laid each season do not survive to hatching, either as a result of developmental issues or predation (Caroffino et al. 2010). Though difficult to quantify, predation on the newly-hatched larvae is also assumed to be very high, and experiments with captive predators appear to show a preference for sturgeon larva (E. Baker, MI Dept. Natural Resources). Juveniles are vulnerable to predation until they reach 160mm in length, after which mortality rates decline dramatically (E. Baker, MI Dept. Natural Resources). Lake sturgeon reach sexual maturity after 12-15 years (for males) and 14-20 years (for females), which is late in life even among sturgeons. For example, female Atlantic sturgeon (*A. oxyrinchus*) mature at 8-14 years old (Chebanov and Galich 2013), white sturgeon (*A. transmontanus*) at 12 years old, and giant beluga

sturgeon (*Huso huso*) mature after 15-18 years (Gesner et al. 2014). All of these species reach larger sizes than lake sturgeon. After maturing, sturgeon return to their natal stream and spawn intermittently throughout their lives. As females grow, their fecundity increases exponentially with body mass, making older, larger females particularly valuable to populations (Baker and Auer 2013).

HISTORY OF STURGEON IN THE GREAT LAKES

Prior to European colonization of the Great Lakes region, lake sturgeon were remarkably abundant, and it is believed that all major tributaries supported spawning populations. Evidence of sturgeon fishing by aboriginal peoples dates from at least 2,000 years ago. Unfortunately, the abundance and size of lake sturgeon made them a nuisance for European fishermen pursuing other species, and sturgeon became targets for deliberate destruction after the region was settled. Accounts exist of lake sturgeon carcasses stacked on the decks of steamships for use as fuel, reflecting both their past abundance and an apparent disdain for the species before fishermen recognized their potential value (Carey 2005). Because of their long maturation time, sturgeon populations are very sensitive to the removal of adult fish, and populations of lake sturgeon quickly began to decline. This decline was exacerbated by the concurrent alteration of the lake landscape. Damming, channelization, and deforestation eliminated sturgeon spawning habitat across their range, severely curtailing capacity to sustain populations. The economic value of lake sturgeon became known to commercial fisheries in the late 1800's. Though the primary value of lake sturgeon lay in caviar and meat, nearly every part of the fish could be used in some manner. Overfishing accelerated, with preferential harvest of the large individuals, which are most valuable for reproduction (Dempsey 2013). By the mid-1900's, lake sturgeon fisheries around the Great Lakes had collapsed. Lake Michigan's fishery production fell from over 3.8 million pounds in

1880 to 2,000 pounds in 1929, at which point the commercial fishery was closed (U.S. Fish and Wildlife Service 2016). Current population estimates are 1% of levels prior to colonization (Dempsey 2013).

After the collapse of sturgeon populations across their range, conservation and rehabilitation programs were instituted by American, Canadian, and First Nations governments as early as the turn of the 20th century (Post 1890). The remaining populations are now strictly managed, and measures are in place to protect the largest and most fecund sturgeon. In addition, hatching programs are used to supplement or reintroduce populations in some river systems. Research on the captive rearing of sturgeon began in Russia in 1870 and the United States in 1875 (Conte et al. 1988). Today, many species are raised in hatcheries and farms. Though lake sturgeon are not among those sturgeon raised for commercial aquaculture, captive rearing has occurred since the late 19th century for the purpose of stocking (Post 1890). However, even with strict management and stocking programs, lake sturgeon numbers have been very slow to recover, and adjustments in stocking protocols are continuously being implemented.

One recent innovation has been the development of mobile sturgeon hatching trailers designed by the Little River Band of Ottawa Indians. These trailers operate as portable streamside hatcheries which may be parked beside a river selected for stocking, then plumbed to draw water from the river in a flow-through system. This improves the chances that the sturgeon will imprint on a given river and return to spawn in the future (Holtgren et al. 2007).

STRESS AND ENDOCRINE GROWTH CONTROL

Stress can be understood as a state of threatened homeostasis. Stressors may be chemical, physical, or otherwise perceived, and may stimulate a physiological response that is intended to restore a normal homeostatic state (Chrousos 1998).

Stress response in fish has been studied extensively. When a fish perceives a stressor, the sympathetic nervous system stimulates the immediate release of catecholamines (Reid et al. 1998). A more delayed response is the release of cortisol. Long-term stress exposure stimulates the release of corticotropin-releasing hormone (CRH) from the hypothalamus, which then stimulates the release of adrenocorticotropin (ACTH) from the anterior pituitary. Adrenocorticotripin then stimulates the release of the corticosteroid cortisol from interrenal cells in the kidneys (Nandi 1962). The circulating free cortisol acts as an intracellular signal by passing through cell membranes and binding to receptor proteins, which act to promote or reduce the activity of various genes. Cortisol release is regulated through negative feedback at all levels of the hypothalamus-pituitary-interrenal axis. The initial release of cortisol in response to stress has a lag time of several minutes, thus it is possible to handle fish and measure resting cortisol levels if samples are collected quickly (Gamperl et al. 1994). By using increases in cortisol concentration as an indicator, it is possible to obtain a relative measure of stress in fish (Barton and Iwama 1991). Cortisol is a highly conserved steroid in vertebrates, but it has many diverse and complex effects across taxa depending on the type of receptors available for binding. Effects of increased cortisol include changes in metabolism, osmoregulatory disturbance, growth rate, and behavioral patterns. In hatchery programs, managers are interested in controlling and minimizing stress because the stress response causes fish to divert energy away from the growth process and may increase susceptibility to disease.

Increased cortisol release in response to stress may be highly variable between different taxa and species of fish. Plasma cortisol concentrations of pallid sturgeon (*Scaphyrinchus albus*) and a hybrid of pallid and shovelnose sturgeon (*S. platyrhynchus*) increased from 2.3 ± 0.3 ng/mL and 2.2 ± 0.4 ng/mL respectively to 3.0 ± 0.3 and 3.2 ± 0.3 ng/ml after being handled. Several species of salmonid and percoid fishes displayed more than tenfold increases in concentration when subjected to the same stressor (Barton 2002). It is also interesting to note that white sturgeon (*A. transmontanus*) reached 40 ng/mL, so it is probable that not all sturgeons experience muted corticosteroid response to stress like pallid and shovelnose sturgeon (Belanger et al. 2001). Though the magnitude of cortisol response differs among taxa, the presence of an increase in cortisol remains a useful indicator of stress. However, it is not clear whether relatively high or low corticosteroid levels indicate whether fishes are “more or less stressed” or if the fishes have different response capacities to stressors (Barton 2002).

Vertebrates produce the hormones triiodothyronine (T_3) and thyroxine (T_4) in the thyroid gland. Though the hormones themselves are highly conserved, the functions are specific to different taxa (Power et al. 2001). The various actions of thyroid hormones are determined by the structure of nuclear receptor proteins, which activate or suppress genes, eliciting diverse responses to a single signal (Yen and Chin 1994, Wu and Koenig 2000). The thyroid axis is also very conserved across different taxa. The release of thyroid hormones begins with thyrotropin-releasing hormone from the hypothalamus, stimulating the release of thyroid-stimulating hormone from the pituitary gland, which then stimulates the production and secretion of T_3 and T_4 from the thyroid gland (Power et al. 2001).

The main hormone secreted by the thyroid gland is T_4 , which is considered to be mostly inactive in relation to metabolic change, with few functions except as a precursor for T_3 . The

relatively inactive T₄ is converted to T₃ via enzymatic removal of one iodine unit from the outside ring (Eales and Brown 1993). Thyroid hormones are most often circulated in plasma while bound to thyroid-hormone-binding proteins. However, thyroid responses in fish are usually measured in terms of unbound T₃ and T₄ circulating in the bloodstream (Refetoff 1979).

Thyroid hormones have been linked to a wide variety of responses in fish development. Most teleost fish undergo three developmental stages after hatching: larval, juvenile, and adult, of which the transformation from larva to juvenile is the most striking. The metamorphosis from larva to juvenile consists of a variety of physiological and morphological changes, and studies of many fish species have found these changes to be dependent on changes in thyroid hormone levels (Power et al. 2001). More specifically, levels of free T₃ and T₄ in Amur sturgeon (*A. schrenckii*) were found to be inversely related with stocking density and correlated with growth rates (Li et al. 2012).

GROWTH COMPENSATION

Fish may experience reduced growth as a result of environmental influences. For example, decreased water temperature causes a decrease in both growth and metabolic rate in fish within appropriate thermal tolerances (Fonds et al. 1992; Nicieza and Metcalfe 1997). Increasing fish biomass in a tank also limits growth rate (Szczepkowski et al. 2011). Obviously, starvation will also reduce the rate of growth (Nicieza and Metcalfe 1997), and sturgeon are no exception (Hui et al. 2011; Liu et al. 2011; Yarmohammadi et al. 2013). However, following periods of reduced growth, many fish undergo accelerated, or compensatory, growth when conditions improve. Following a period of starvation, fish returned to normal feed often show growth rates greater than those of control groups until they have “caught up” (Russell and Wootton 1992; Szczepkowski et

al. 2011). This capacity to recover from a short-term stressor is a valuable asset in a variable environment, although compensatory growth has been linked to increased winter mortality in brown trout (*Salmo trutta*) (Johnsson and Bohlin 2006).

Growth compensation has also been demonstrated in several species of sturgeon, including Siberian (*A. baerii*) (Morshedi et al. 2013), Chinese (*A. sinensis*) (Liu et al. 2011), and Persian sturgeon (*A. persicus*) (Yarmohammadi et al. 2013), though this phenomenon has not been well-studied in lake sturgeon.

CHAPTER 2: GROWTH PATTERNS AND SIZE-GROUP INTERACTIONS IN HATCHERY-RAISED AGE-0 LAKE STURGEON

INTRODUCTION

The lake sturgeon (*Acipenser fulvescens*), like all members of the sturgeon family, is a species of special conservation concern throughout its range. Historically the subject of deliberate destruction, overfishing, and habitat loss, lake sturgeon populations are currently estimated to be at about 1% of historical levels (Dempsey 2013). Due to careful management practices, the species is now considered of “Least Concern” by the International Union for the Conservation of Nature (IUCN) (St. Pierre, R. and Runstrom 2014). However, lake sturgeon require a long time to mature (up to 20 years for females) experience high mortality of young, thus stocks have been slow to recover from historic lows (Baker and Auer 2013). To assist in population rehabilitation, American, Canadian, and First Nations governments have instituted captive breeding programs that include both permanent traditional hatcheries and portable streamside facilities (Holtgren et al. 2007).

Recent data from the Black River Streamside Hatching facility (Onaway, MI) indicates that survival of captive-reared lake sturgeon is greatest when stocked fish are at least 160mm total length (TL) at time of stocking (personal communication, E. Baker, MI Dept. of Natural Resources). Achieving that target length is not easy when raising sturgeon because sturgeon produce wide size distributions when raised in captivity, and many individuals do not reach 160mm before being released. In 2015, fish released in the Whitefish and Cedar Rivers of upper Michigan ranged from 110 to 185mm (6 to 26g) and 125 to 190mm (8 to 26g) TL, both averaging slightly below 160mm TL (personal communication, E. Baker, MI Dept. of Natural Resources). Assuming a normal size distribution, this suggests that approximately half of the lake sturgeon

stocked each season are at increased risk of mortality. Investigating why some sturgeon grow more slowly than conspecifics and evaluating techniques to mitigate this pattern may allow hatchery managers to increase overall growth rate, thereby improving the effectiveness of stocking programs.

Differences in growth rate among fish may be the result of many factors. Growth rates are generally accepted to be positively correlated with food availability, though experiments have demonstrated that above a certain point increased ration will not enhance growth further (Deng et al. 2003). Unlike many species, lake sturgeon in captivity typically refuse to eat commercial fish foods (Anderson and Latta 1984). Instead, they must be fed a diet of brine shrimp followed by frozen bloodworms at a rate of 2-5% (dry mass) per day (Bauman et al. 2016). In practice, the bloodworms are dropped into tanks that may hold several hundred sturgeon, thus there is no guarantee that each individual consumes an equal portion of the available food. Though lake sturgeon are not thought to develop size-related dominance hierarchies like salmonids (Allen et al. 2009), it is still possible that some individuals may feed more vigorously than others, thus increasing their own growth rate while limiting that of their tankmates. Congeners of lake sturgeon undergo compensatory growth following a period of starvation (Liu et al. 2011; Morshedi et al. 2013; Yarmohammadi et al. 2013). Therefore, if the small sturgeon are experiencing limited growth from food deprivation, then the small lake sturgeon may undergo compensatory growth if separated from larger individuals.

Another factor that affects growth rate is the amount of stress experienced by individual fish. Although all sturgeon in one tank should experience the same water quality, temperature, and disturbance from cleaning, it is possible that individuals experience differing levels of stress from the same stressor. Because increased stress is known to divert metabolic resources away from

growth, different levels of stress response may result in different growth rates. Using plasma cortisol levels as an indicator, it is possible to compare the stress responses between fast- and slow-growing individuals. The second objective of this study was to test the possibility that differential stress responses cause differential growth rates in lake sturgeon reared in the same tank. If stress is a significant factor limiting the growth of certain sturgeon more than others, the smaller size groups should exhibit higher concentrations of plasma cortisol than larger fish.

Slower growth rates may also be indicative of differences in thyroid hormone activity. Although thyroid hormones are generally associated with metamorphosis in fishes, they are also positively correlated with growth rates in Amur sturgeon (*A. schrenckii*) (Li et al. 2012). Different plasma thyroid hormone levels may directly impact the growth rate of lake sturgeon, or it may be that some outside phenomenon limiting growth rate also delays certain early developmental milestones. In either case, the larger size group of lake sturgeon should exhibit higher plasma concentrations of triiodothyronine and thyroxine.

METHODS

On June 5th, 2016 we acquired 40ml of fertilized lake sturgeon eggs (approximately 2000 individuals) from the Black River streamside hatching facility in Onaway, Michigan with permission from the Michigan Department of Natural Resources and in accordance with NMU IACUC protocols for captive-handling fish. The eggs were a result of a single male/female cross and had been stirred with fine clay to prevent adhesion during incubation. The eggs were transported to the Northern Michigan University Aquatics lab and placed in two 2-liter Pentair Mini-Egg conical hatching jars with larval collectors (Pentair Aquatic Eco-Systems, Cary, NC). Each hatching jar and larva collector was mounted on a three-tank recirculating system consisting

of three 500L round tanks (figure 2), each equipped with a Lifeguard QL-40 Ultraviolet sterilizer (Lifeguard Aquatics, Cerritos, CA), a Jacuzzi cartridge particle filter (Jacuzzi, Inc.), a paper-shred biofilter, and an aerator. The tank systems were filled with dechlorinated water from the Marquette, MI city water supply. The tank outflows were covered with plastic mesh, and the mesh size was adjusted as the lake sturgeon grew to prevent fish from being trapped in the pipes. The tank sides and mesh covering the outflow pipes and particle filters were cleaned weekly to maintain flow and water quality. The water was partially changed once per week at the beginning of the experimental period, and twice per week starting 76 days post-hatching. The water temperature averaged 16.9 ± 0.9 °C among the tanks, and the photoperiod was a constant 12h light, 12h dark cycle.

Any eggs that began to clump together or develop mold during incubation were discarded to prevent the spread of fungal infections. After six days, all viable eggs had hatched. Squares of indoor/outdoor carpet were placed at the bottom of the tanks to provide cover for the negatively-phototactic yolk-sac larvae. The yolk sacs were completely consumed one week after hatching, and the larvae began to emerge from cover to search for food. At this stage, larvae were collected and counted, which revealed 1460 larvae (roughly 73% hatching success). The larvae were then reallocated evenly between the two replicate tank systems. Once the lake sturgeon began exogenous feeding, they were fed lab-cultured brine shrimp (premium shrimp cysts from Brine Shrimp Direct, Ogden, UT) to excess. Seventy-one days after hatching, the lake sturgeon were weaned from brine shrimp onto frozen bloodworms (Brine Shrimp Direct, Ogden, UT) over the course of a week. After conversion to bloodworms, fish were fed at a rate of 40% of total tank biomass per day (two feedings of 20% per day), and a subset of fish from each tank was weighed every week to obtain average body weight. This average body weight was then used to estimate the total biomass of the tank and adjust the feed rate.

Biweekly fish sampling, during which 100 fish from each system were randomly selected and measured for length and weight, began 72 days post-hatch. All sampling began at 1:00pm. The first eight sturgeon per tank were sacrificed to obtain blood samples from the caudal vessels using heparin-coated capillary tubes; samples were collected in less than 5 minutes from disturbance and kept on ice. The bled sturgeon were then euthanized using tricaine methanesulfonate overdose. After collection, blood samples were centrifuged for 5 minutes. The plasma samples were then stored at -80°C for later analysis.

All remaining sturgeon were collected from both systems 107 days after hatch, and divided into size classes by length. Between onset of exogenous feeding and separation, 521 lake sturgeon died, leaving 939 individuals. Lake sturgeon ≥ 90 mm total length were assigned to the Large size class, sturgeon from 80 to 89mm were assigned to Medium, and those ≤ 79 mm were assigned to Small. The number of sturgeon in each tank was adjusted to balance initial biomass among the size class groups, and dispersed equally between the replicate tank systems resulting in one tank with each size class in each system. Each Large tank began with 71 fish, each Medium tank with 97 fish, and each Small tank with 140 fish. Biomass was standardized to avoid effects of biomass load on growth rates. Seventy lake sturgeon from each tank were tagged with individually-numbered Visible Implant tags (2.7mm x 1.2mm) from Northwest Marine Technology (Shaw Island, WA) under the skin between the mouth and barbels using an injector needle.

After separation of size groups, sampling continued at two-week intervals. Length, weight, and tag numbers were recorded for 50 sturgeon from each tank, and the first eight fish were bled within five minutes of first handling (with the exception of two sampling events on November 6th and 20th in which 10 fish per tank were bled). The final data were collected 186 days after hatching. After sampling, the remaining 349 sturgeon were transported to Otsego Lake for release with

Michigan DNR permission. After separation, all mortalities occurred during blood sampling, with the exception of two mortalities in the Small group of System 1. In total, 1328 lake sturgeon died during the course of this study, 265 as a result of blood sampling, and 1063 mortalities due to other causes, while 323 individuals were removed from the study when size groups were separated (Figure 1).

Concentrations of free plasma cortisol in each sample were measured using enzyme immunoassay (EIA) kits from Arbor Assays (Ann Arbor, MI), which used monoclonal mouse antibodies binding to cortisol and goat anti-mouse antibody plates to bind the mouse antibodies. Free T₃ and T₄ were measured using EIA kits from MP Biomedical (Solon, OH), which used competitive binding of free thyroid hormones and hormone conjugate to monoclonal antibodies on the plates. Six fish per sample were assayed for cortisol and T₃, while T₄ assays were conducted on the remaining samples. All samples were measured in duplicate wells, and the standards in quadruplicate, using a Biotek Epoch 2 microspectrometer (Biotek, Winooski, VA) at 450nm. Concentrations were calculated based on standard curves using Biotek Gen 5 analysis software

Data analysis:

Changes in length and weight data between sampling events were analyzed for significant differences between size groups using analysis of covariance, with α set at 0.05. The initial length or weight for each growth interval was used as a covariate when analyzing growth, and the analysis also evaluated differences between tank systems. One-way analysis of variance was used to analyze differences in individual growth rates among tagged fish of different size groups. Tags that could not be confidently read were omitted from analysis. Plasma concentrations of cortisol were analyzed using analysis of covariance, with time as the covariate. Plasma concentrations of

T₃, and T₄ were analyzed using one-way analysis of variance. All statistical analyses were completed using IBM SPSS v22 (Armonk, NY).

RESULTS

Growth Rates

After the experimental period began 72 days post-hatching, the mean length and weight of all size groups increased exponentially until the end of the experiment (Figure 2). The lengths and weights of the three groups diverged over the course of the study, and at no point after separation did the smaller size groups approach the size of the Large group. Following separation into size categories 107 days post-hatching, the three groups remained different in mean total length ($F=1085.198$, $df=2$, $P<0.001$) and weight ($F=448.316$, $df=2$, $P<0.001$) until the end of the experiment, maintaining the large, medium, and small size-class distinctions. The growth patterns of the two tank systems (Figure 1) were similar for length, but the profiles differed in weight growth pattern near the end of the experimental period. The average weights of the various size groups became closer in system 1 at the very end of the experiment, but diverged in system 2. Rates of weight increase between the two tank systems differed ($F=54.025$, $df=1$, $P<0.001$), but growth rates among size categories did not ($F=0.580$, $df=2$, $P=0.575$; $F=2.732$, $df=2$, $P=0.110$). These results do not support evidence of growth compensation following size class separation.

At the time of separation, the length-frequency distributions of the three size groups resembled a bell-shaped distribution divided into three sections. None of the three groups had a normal distribution at separation (Small: Shapiro-Wilk=0.912, $P<0.001$; Medium: Shapiro-Wilk=0.954, $P<0.001$; Large: Shapiro-Wilk=0.889, $P<0.001$). By the end of the experimental period, the distributions of each group had become much broader, and the Medium and Large

groups were normally distributed based on size frequencies (Medium: Shapiro-Wilk=0.983, $P=0.246$; Large: Shapiro-Wilk=0.987, $P=0.651$) (Figure 4). The Small size group was not normally distributed (Shapiro-Wilk=0.971, $P=0.024$), but was much less skewed than the initial distribution, and showed a much wider range in sizes. When viewed together, the distributions of the three size groups at the conclusion of the experiment overlapped (Figure 5). Thirty-seven percent of sturgeon in the Small size group fell within the range of the Large size group, and 74% fell within the range of the Medium size group. Additionally, 84% of sturgeon from the Medium size group fell within the range of the Large size group.

Tag readability declined over the course of the study. Tags were either shed into the tank system and lost, or were buried under tissue in the rapidly growing sturgeon until they became unreadable. By the end of the experiment, 16% and 21% of tags were still in place and readable in the Large tanks of each system, 11% and 14% of the Medium tags were readable, and the 6% and 7% of tags were still readable in the Small tanks of the two systems, respectively. The probability of retaining legible tags appears to be positively correlated with size at the time of tagging.

Analysis of the average size of individually tagged fish mirrored that of average growth rates. Average growth rates of the tank systems were not different ($F=8.047$, $df=1$, $P=0.055$), and the rate of change in all three size categories was similar ($F=0.966$, $df=2$, $P=0.412$). All tagged individuals increased in size, but of those whose growth could be tracked from separation until the end of the experimental period (Figure 6), several small individuals within each size group increased their size rank relative to others, thereby demonstrating increased growth rates. Four such individuals (44%) from the Small size group clearly demonstrated increased relative growth rates that resulted in rank changes, and six individuals (25%) did so in the Large size group, while only one (12.5%) tagged sturgeon noticeably increased rank in the Medium group. In addition, the

instantaneous growth rates of individuals tracked over the entire experiment (Figure 7) were greatest in the small size group ($F=28.649$, $df=2$, $P=0.001$). Therefore, while average size of tagged individuals remained different between groups, the small size group demonstrated the fastest growth rate relative to their size.

Plasma hormone levels

The mean plasma cortisol concentrations (Figure 8) were highly variable and had no obvious pattern, except that all three size groups ended the experiment with lower concentrations of plasma cortisol than at separation. Average plasma cortisol levels did not differ among size groups ($F=0.079$, $df=2$, $P=0.924$). Analysis of plasma thyroid hormone concentrations (Figure 9) yielded similar results, though not enough plasma was available from early samples to trace changes across the entire experiment. Additionally, not enough plasma serum was available to assay both T_3 and T_4 in the same sturgeon, so T_3/T_4 ratios could not be evaluated. Thyroid hormone concentrations did not change significantly over time, either in T_3 ($F=0.043$, $df=1$, $P=0.836$) or T_4 ($F=0.427$, $df=1$, $P=0.517$). Mean T_3 concentrations also did not differ among size groups ($F=0.408$, $df=2$, $P=0.615$), nor did concentrations of T_4 ($F=0.755$, $df=2$, $P=0.477$).

DISCUSSION

Growth rate patterns

Following separation into size classes 107 days post-hatch, the Medium and Small size groups of sturgeon did not grow faster than the Large size group in average length or weight, indicating no growth compensation. Based on the lack of obvious compensatory growth, it is probable that the lake sturgeon in this study did not undergo a starvation response similar to deliberate starvation studies in other species (Liu et al. 2011; Yarmohammadi et al. 2013; Morshedi et al. 2013). Thus, it appears that interaction between large and small lake sturgeon in a

tank does not cause starvation in smaller individuals. This also suggests that separating small and large hatchery sturgeon is not an effective method to increase the growth rate of small individuals when food is supplied in excess, and therefore would likely not increase stocking efficiency.

Between separation into size categories and the end of the experimental period, the size distributions within all three categories broadened. The Large and Medium size groups developed normal size-frequency distributions. A similar pattern was reported by Fajfer et al. (1999) where a plot of weights over time in three different densities of sturgeon showed increasing variability in all groups. Wild juvenile European sea sturgeon (*A. sturio*) also showed increasing size variation in both experimental and control groups of age-0 fish during five years of captivity, despite a high probability of all individuals sharing a mother and father (Williot et al. 2007). Data from individually tagged lake sturgeon in this study revealed that some individuals in the small size group who had the lowest length at separation were among the largest individuals in that group by the end of the experiment. In addition, individual data from tagged fish demonstrated faster growth among small sturgeon relative to initial size. Though the average size of the three groups remained different from separation until the end of the experiment, the different growth rates among tagged fish suggest that compensatory growth did occur.

The consistent differences among the size groups imply that certain individuals will always grow faster than their tankmates, but the rank changes in tagged individuals show that growth rates do change in different ways when the environment is altered. It is accepted that variability occurs on an individual level in organisms, but when raising a species for conservation, it is beneficial to tease out the nuances of this variability. Understanding these subtleties of growth rate variability is the key to fine-tuning the process of hatching and stocking, especially when the ultimate goal is a self-sustaining wild population. For example, if tolerance of life in captivity is variable within a

family, certain individuals may grow faster and be more prone to survival after release. Hatchery managers may therefore inadvertently select for individuals that are more suited for captivity than wild settings. Another potential explanation for the different growth rates could be differences in male and female growth. Unfortunately, immature sturgeon are not sexually dimorphic, and no genetic markers for sex determination have been identified with the possible exception of female white sturgeon (*A. transmontanus*) (Van Eenennaam et al. 1999). This possibility may lead to skewed sex ratios in stocked sturgeon in instances where hatchery managers select larger individuals, but until genetic markers are found there is no way to ascertain whether this is the case without long-term study of tagged individuals in a stocked population.

The tagging method used in this study yielded useful data, but had several drawbacks. Tag retention was greatest among larger individuals at the time of tagging, which created a risk of low data availability among small sturgeon. In addition, some tags became unreadable because they were injected too deeply under the skin, a problem that became more prevalent as the sturgeon grew rapidly and tissue was deposited over the tags. In sacrificed individuals, the tag could be retrieved, but this was not possible for those sturgeon returned alive to the tanks. Therefore, a certain amount of skill is necessary to achieve proper injection depth of the tag to ensure readability. This method of tagging was useful in this study due to the small size of the lake sturgeon at the time of tagging, and also because of the relatively low cost of elastomer tags. However, radio-frequency identification (RFID) tags would likely have made individual identification much easier and more reliable if available in appropriate sizes.

Plasma hormones

The wide range of cortisol concentrations across size groups did not show consistent differences between the three size groups, so it is not likely that differing stress levels are a primary factor determining growth. However, all three size groups did end the experiment with lower cortisol levels than at the time of separation, which may be a result of steadily decreasing biomass densities in all tanks as sturgeon were sacrificed for blood sampling or a developmental shift in production with age.

Studies of plasma cortisol levels as a stress response in sturgeon have reported different levels. Cortisol concentrations in pallid and shovelnose sturgeon reached 3.0 and 3.2 ng/mL respectively (Barton 2002), while Belanger et al. (2001) found concentrations approaching 40 ng/mL in white sturgeon, which indicated that the release of cortisol in response to stress varies across genera. Additionally, fish may become desensitized to a stressor if it is regularly applied, provided it is not immediately lethal (Reid et al. 1998), so individuals reared in different environments or sampled at different ages may display markedly different levels of plasma cortisol in response to the same stressor. However, the plasma cortisol levels in this study were greater than the resting cortisol levels reported by Allen et al. (2009) (~50 pg/mL), but are consistent with elevated levels of the same sturgeon following stress (250-300 pg/mL). Likewise, average plasma cortisol levels of wild adult lake sturgeon measured by Baker et al. (2008) were greater than the cortisol concentrations recorded in this study immediately after the adult sturgeon were handled (498 pg/mL), but were far lower after a three day recovery period (24 pg/mL). Both studies used older lake sturgeon than this experiment, and both studies housed lower sturgeon biomass densities per tank. Furthermore, the sturgeon in this study were housed in recirculating systems in a laboratory environment, whereas other studies used flow-through systems that do not recycle waste water.

Interestingly, despite the apparently elevated levels of cortisol in this study, the experimental lake sturgeon reached a similar size as those raised for stocking purposes in northern Michigan in 2015, which averaged 153mm TL and 15g weight after approximately four months (personal communication, E. Baker, Michigan Dept. of Natural Resources). This may be because plasma cortisol concentrations are an imperfect analog for stress, or it may mean that lake sturgeon grow rapidly in spite of mild stressors in a recirculating system. If the latter, it would lend support to a life history strategy in lake sturgeon that prioritizes rapid growth during the first year of life even under less-than-ideal environmental conditions. This would be a beneficial strategy for maximizing recruitment because young sturgeon are relatively defenseless, but become significantly less vulnerable to predation as they increase in size (Caroffino et al. 2010; Baker and Scribner 2015).

The plasma free thyroid hormone concentrations in this study were consistent across the size groups, and relatively high compared to the results of other studies. Plohman et al. (2002) found that plasma levels of free T₃ and T₄ were very low (2.0 pg/mL and 3.0 pg/mL respectively), in 2-year-old lake sturgeon, though occasionally wild adult sturgeon would exhibit high levels of both. This is likely because thyroid hormones act as signals during metamorphosis between larval and juvenile life stages in fish, and also play a role in physiological changes associated with spawning (Power et al. 2001). Therefore, sturgeon well past metamorphosis and not spawning tend to have low plasma concentrations of free thyroid hormones. In addition, free T₃ is known to have more metabolic effects than free T₄ in fish (Power et al. 2001), so higher levels of plasma T₃ are probably linked to rapid early growth and metamorphosis in lake sturgeon.

Because the levels of free thyroid hormones are tied to metamorphosis and early development, and were consistent across the size groups in this experiment, it suggests that the

timing of metamorphosis was not directly related to the size of each individual. Therefore, the timing of early development milestones may be independent of the rate of growth in lake sturgeon.

This study had several shortcomings. Though the growth rates of the three size groups could be compared to one another to obtain useful data, a comparison to a mixed-size group would have more clearly shown whether separation into size classes led to compensatory growth. Another unavoidable issue was the potential effect of biomass load on growth rates in a tank. Several studies have investigated the effect of sturgeon density on growth rate (Khoroshko and Vlasenko 1970; Fajfer et al. 1999; Szczepkowski et al. 2011; Li et al. 2012), and though Fajfer et al. (1999) found no significant impact of density on growth rates I decided to standardize biomass to avoid potential negative effects. However, it is not known whether growth rates are specifically affected by biomass load, density of individuals, or both equally. Because sturgeon in each size group were different sizes, biomass load and density of individuals could not both be standardized, and there remains the possibility that density of individuals rather than biomass load impacted growth rates. Additionally, collection of some data was hampered by the size of the lake sturgeon. The use of individually-numbered tags yields valuable data, but because the sturgeon in this study were too small to be tagged with passive integrated transponder (PIT) tags it was necessary to use small visible implant (VI) tags. The VI tags used instead had to be read visually, which was not always possible either due to tags being shed or becoming unreadable under layers of tissue. The small size of the sturgeon in this study also limited the availability of plasma samples, which were required for cortisol and both thyroid hormone assays. Samples collected from sturgeon early in the study were often not large enough for all three assays. Specifically investigating the timing of plasma thyroid hormone changes and running a regression analysis of size versus age would yield further information.

In summary, the results of this study were mixed. On average, individuals that were large when separated tended to stay larger than their siblings. On the other hand, tag data show that smaller sturgeon grew faster for their size, indicating some level of growth compensation. Therefore, I recommend that hatchery managers follow one of two plans based on the conditions to maximize sturgeon stocking efficiency. If funds and/or space are limited, hatcheries should raise an excess of sturgeon, and then cull the smaller individuals after metamorphosis in order to focus on those larger sturgeon most likely to reach the target size, thereby reducing cost for food. Alternatively, if resources are more readily available, managers may plan multiple releases in their stocking timeline to maximize output. Because no groups experienced a decrease in growth rate as a result of separation, hatchery staff may still separate large and small sturgeon at a given point and use stocking pulses based on when each size group reaches the target length for optimum survival. This second option would reduce cost of facility operation, but not as much as the first option which produces fewer sturgeon. However, this option does produce more sturgeon more efficiently than releasing all individuals in a single release pulse, and should be favored as a restoration strategy if resources permit.

Size group (tank system)		Small (1)	Medium (1)	Large (1)	Small (2)	Medium (2)	Large (2)
Abundance	Separation	141	97	71	141	97	71
	End of experiment	93	51	27	96	53	27
Biomass	Separation	0.213	0.212	0.209	0.209	0.219	0.212
	End of experiment	1.558	0.931	0.579	1.122	0.869	0.529
Density (individuals/m²)	Separation	57.688	39.686	29.048	57.688	39.686	29.048
	End of experiment	38.049	20.866	11.047	39.277	21.684	11.047
Density (kg/m²)	Separation	0.087	0.087	0.085	0.085	0.090	0.087
	End of experiment	0.637	0.381	0.237	0.459	0.356	0.216

Table 1: Abundance, biomass, and densities of sturgeon in all tanks at time of separation into size groups (107 days post-hatch) and the end of the experiment (191 days post-hatch).

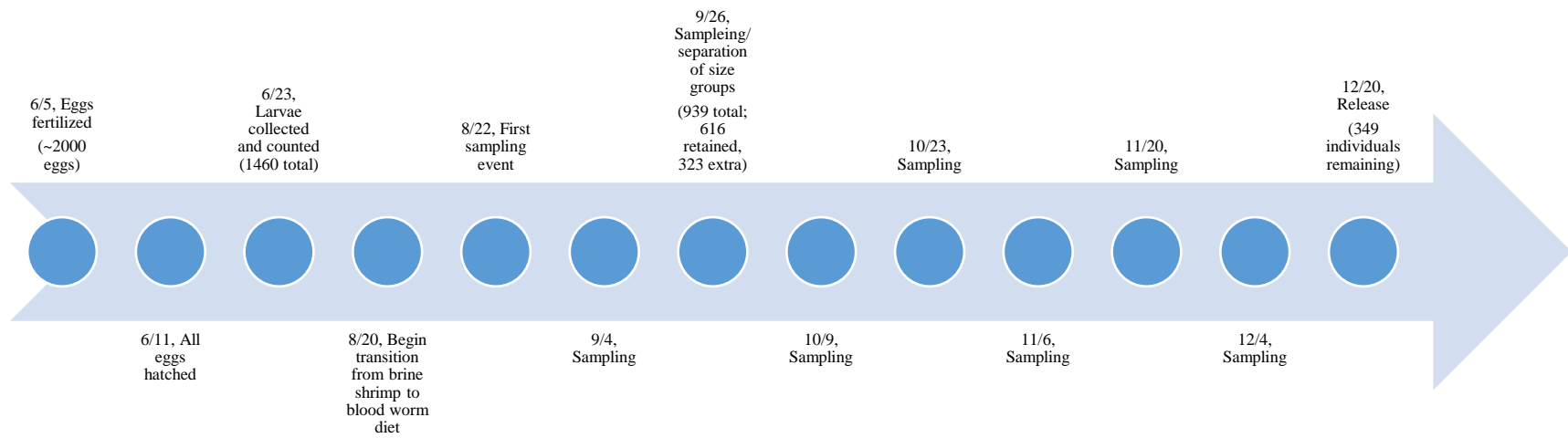

Figure 1: Experiment timeline from egg fertilization to release of remaining sturgeon.

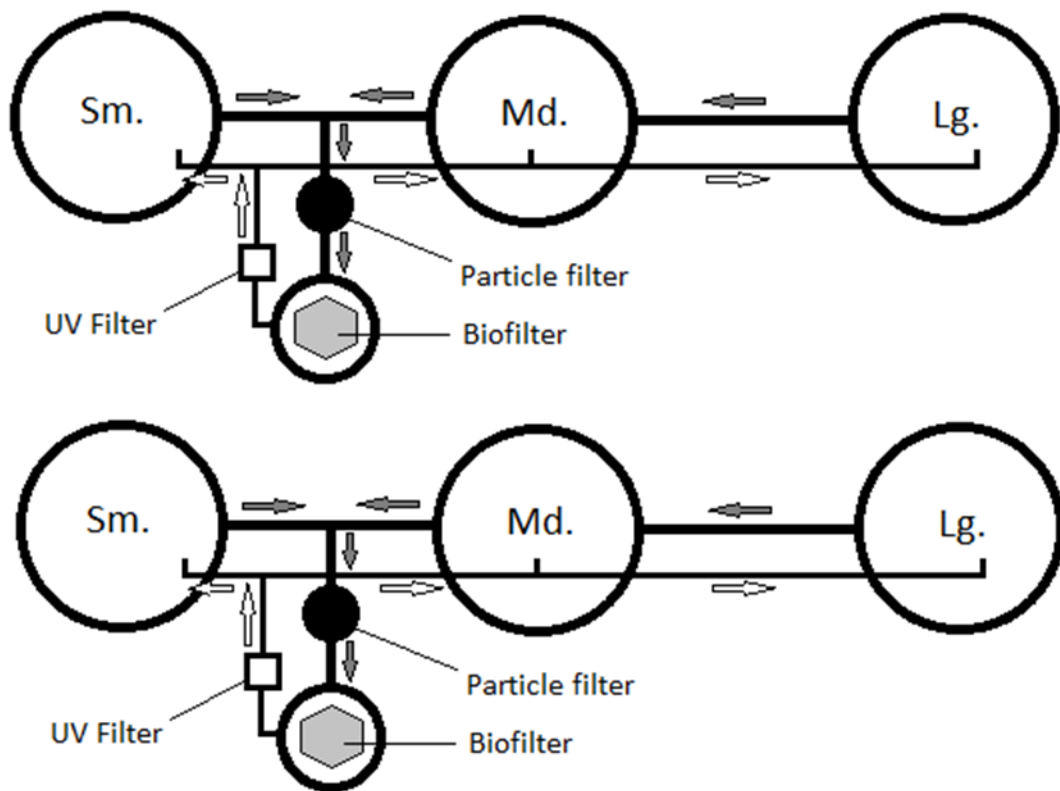

Figure 2: Recirculating tank systems (Sm: small size group, Md: medium size group, Lg: large size group), including filters (filtered water flow shown as light arrows, waste water as dark arrows).

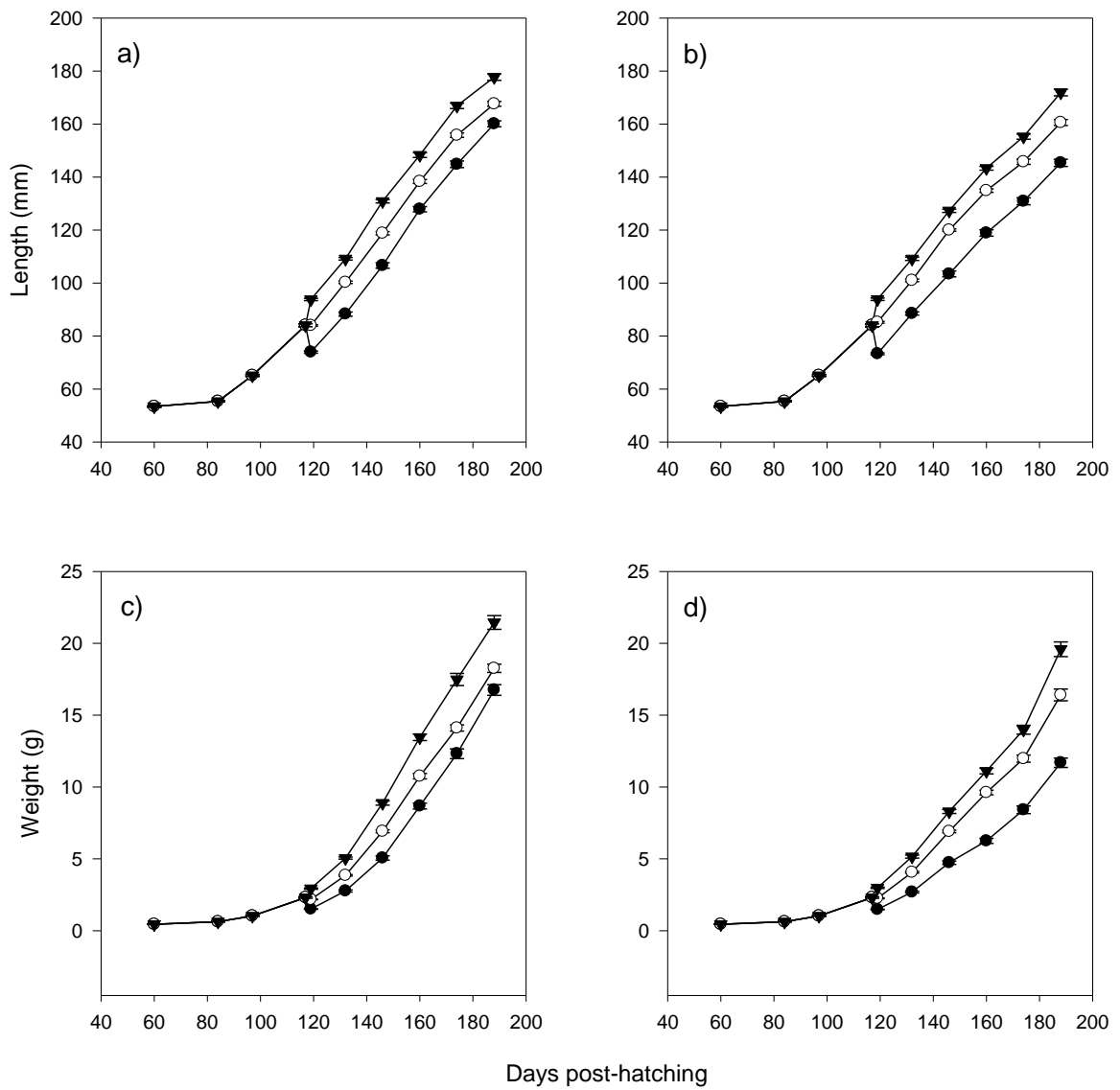

Figure 3: Mean total lengths of sturgeon in each size group (Small:●, Medium:○, Large:▼) from tank system 1 (a) and system 2 (b) and mean weights of sturgeon from system 1 (c) and system 2 (d) with standard errors represented by error bars.

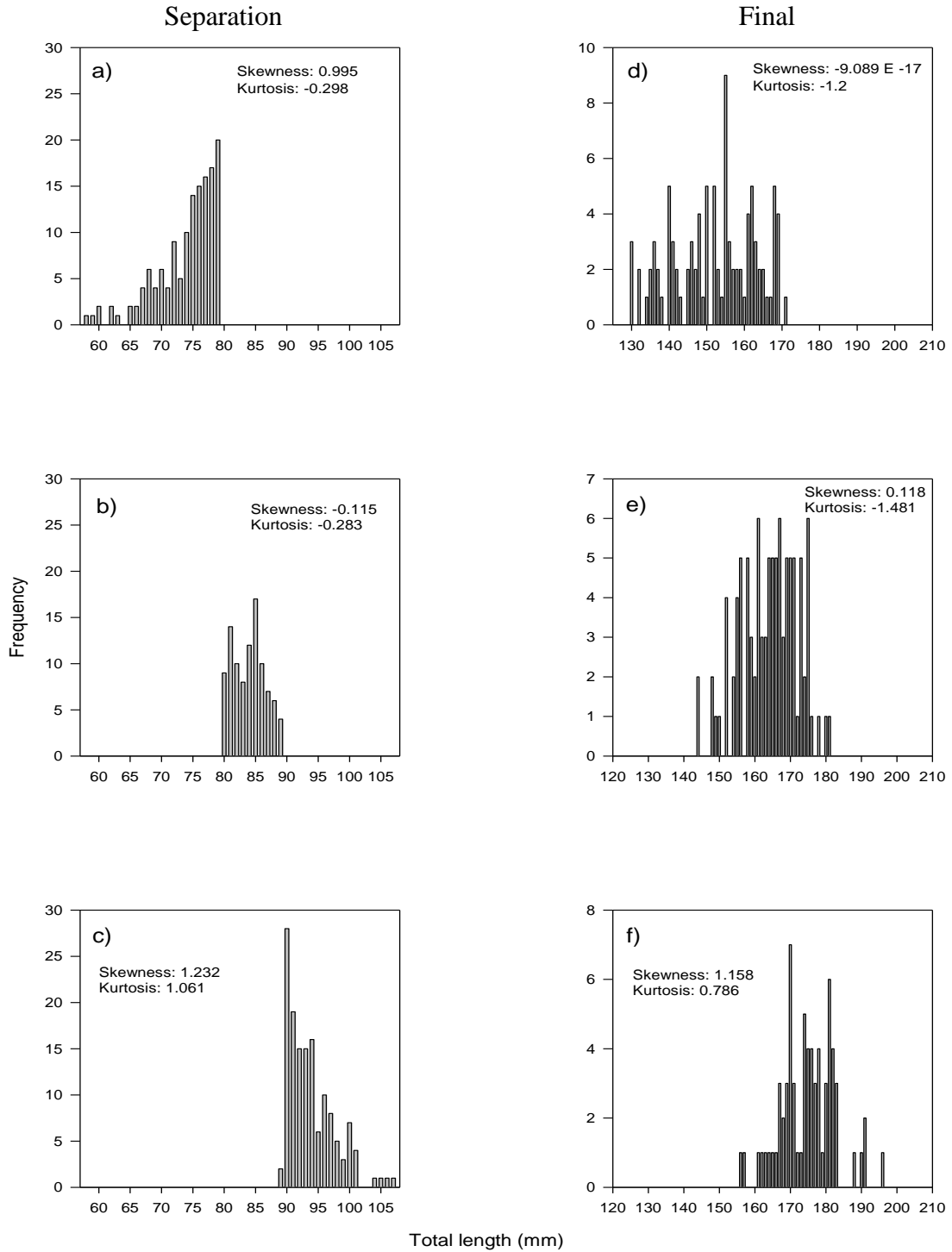

Figure 4: Total length-frequency distributions of sturgeon in Small (a, d), Medium (b, e) and Large (c, f) size groups at time of separation (a, b, c) and the end of the experimental period (d, e, f).

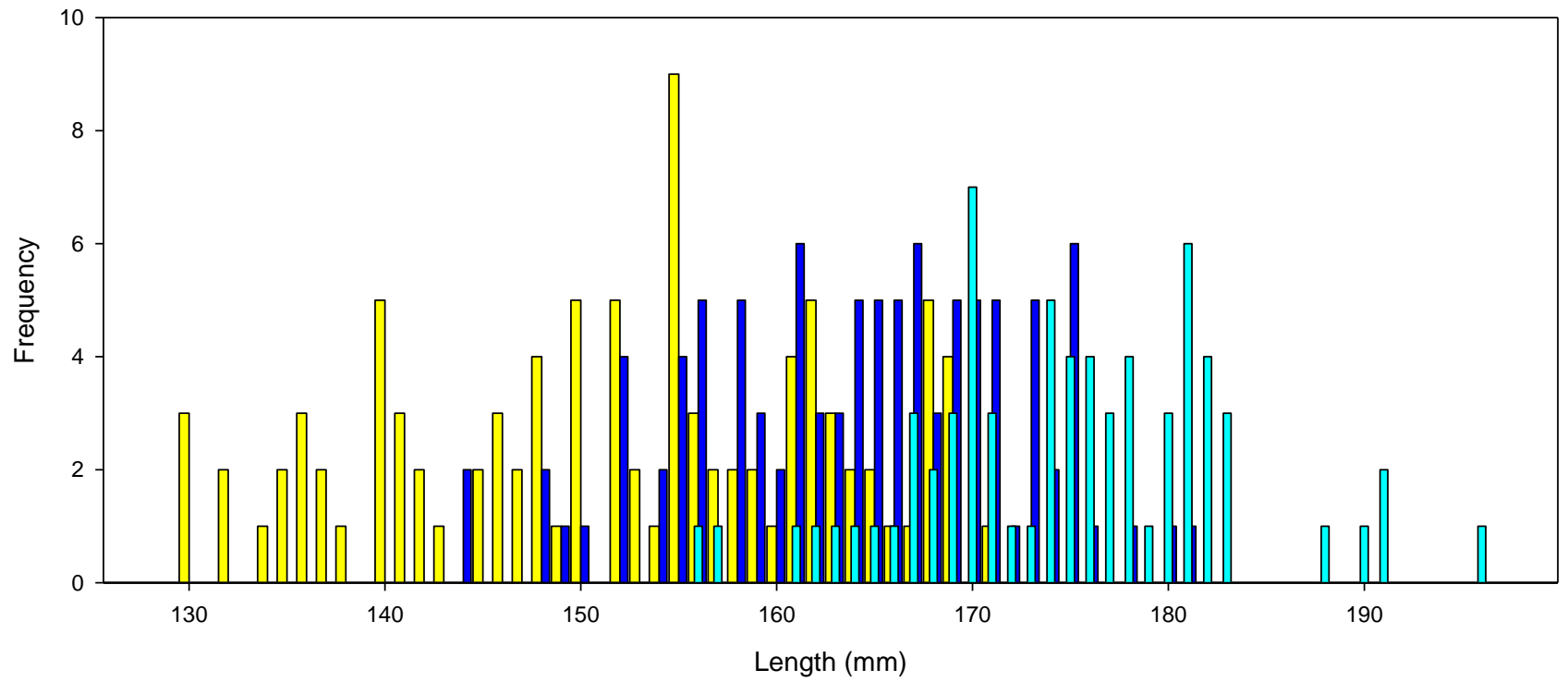

Figure 5: Length-frequency distributions of sturgeon from all three size groups superimposed to show overlap (Small: yellow, Medium: dark blue, Large: light blue).

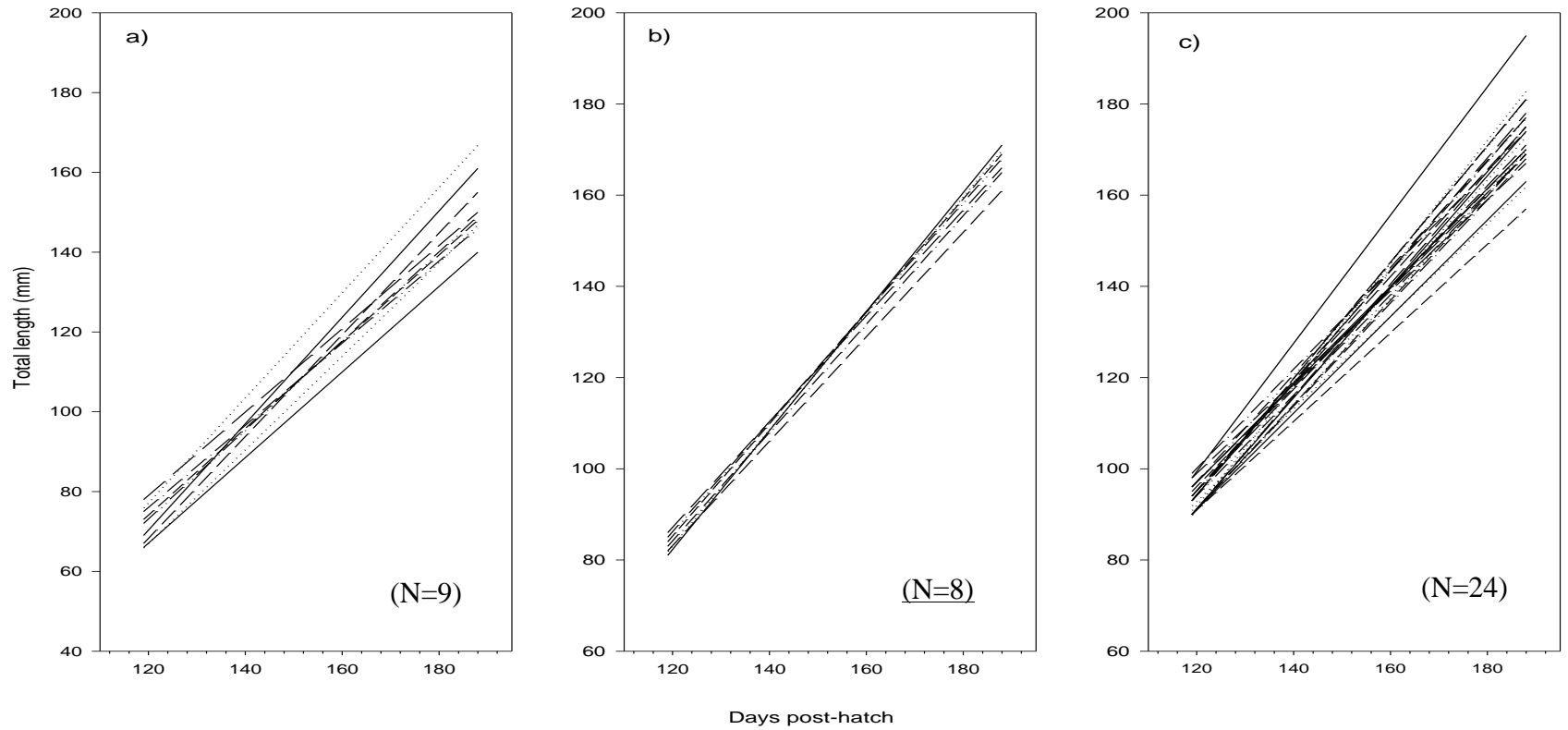

Figure 6: Change in total length of tagged individuals in Small (a), Medium (b), and Large (c) size groups over time from separation to the final sample collection. Each line represents change in size of a single individual. Four of nine small individuals (44%), one out of eight medium individuals (12.5%), and six out of twenty-four large individuals (25%) increased rank.

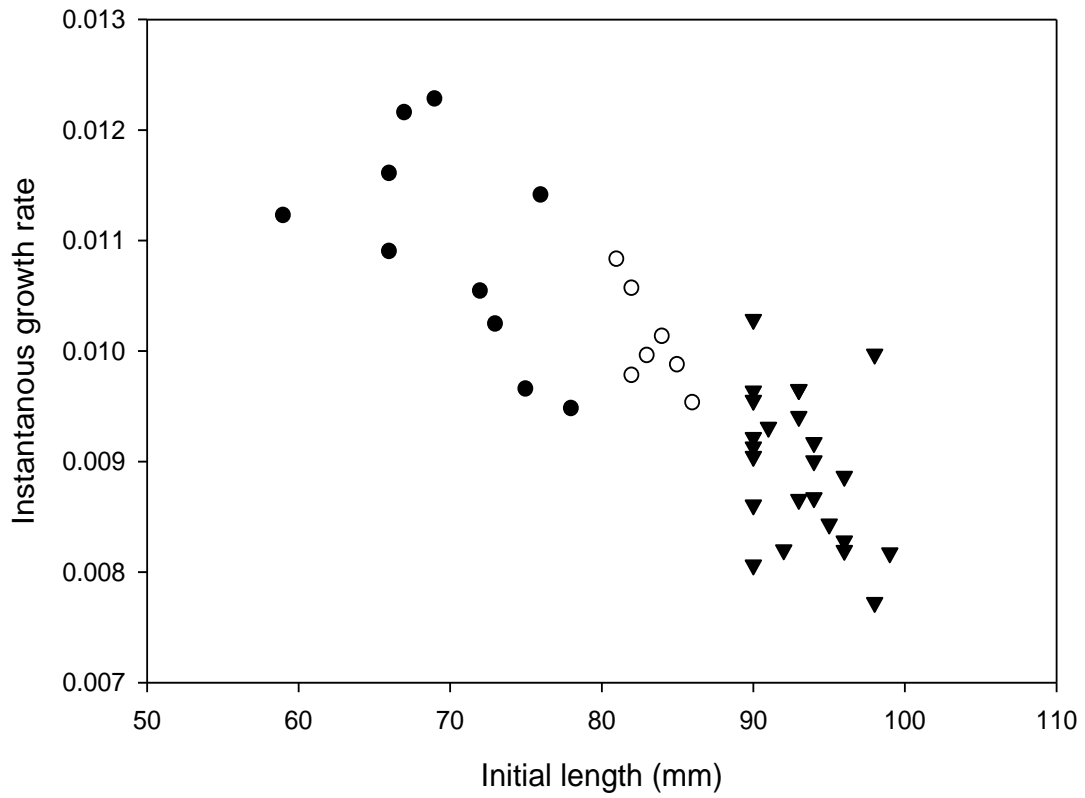

Figure 7: Plot of instantaneous growth versus initial length of tagged sturgeon from each size group (Small: ●, Medium: ○, Large: ▼) from time of separation (107 days post-hatch) until the conclusion of the experiment (186 days post-hatch).

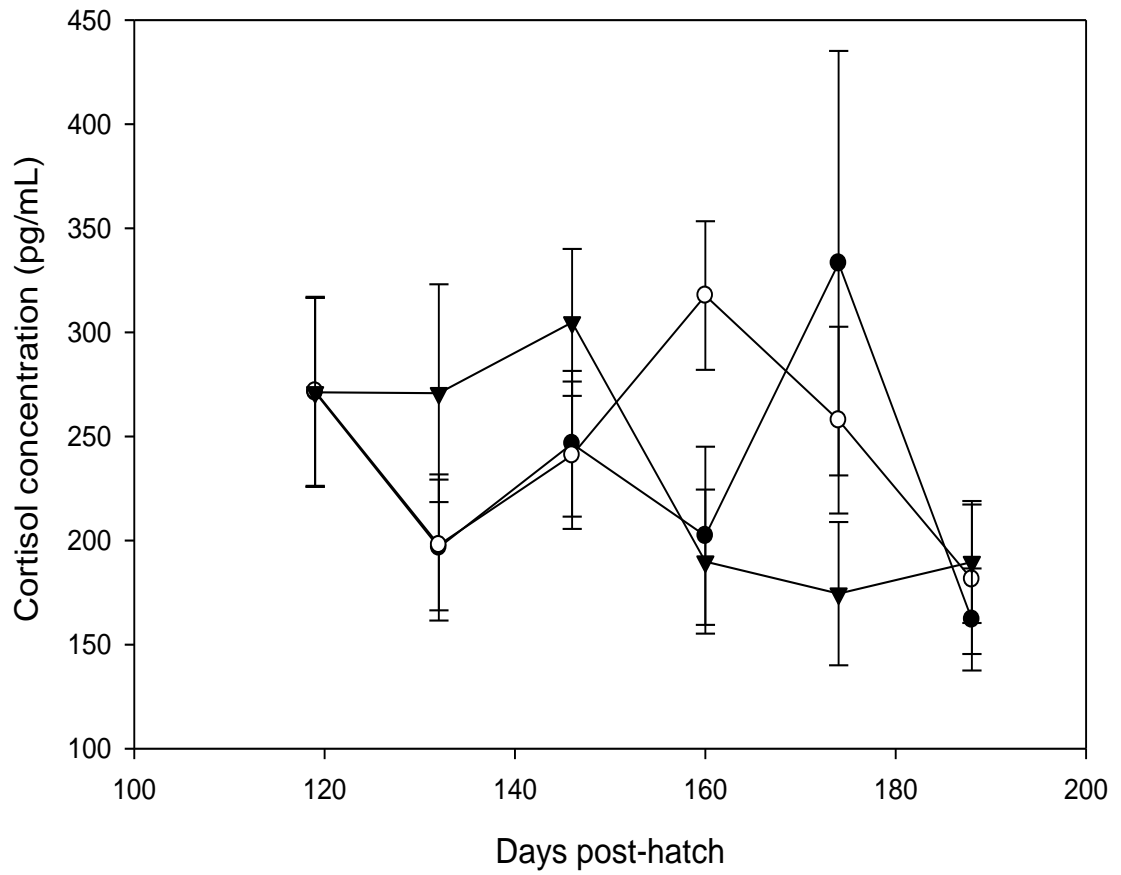

Figure 8: Mean plasma cortisol concentration (pg/mL) of sturgeon in each size group (Small:●, Medium:○, Large:▼) collected at 1400 over the course of the experiment with standard errors shown.

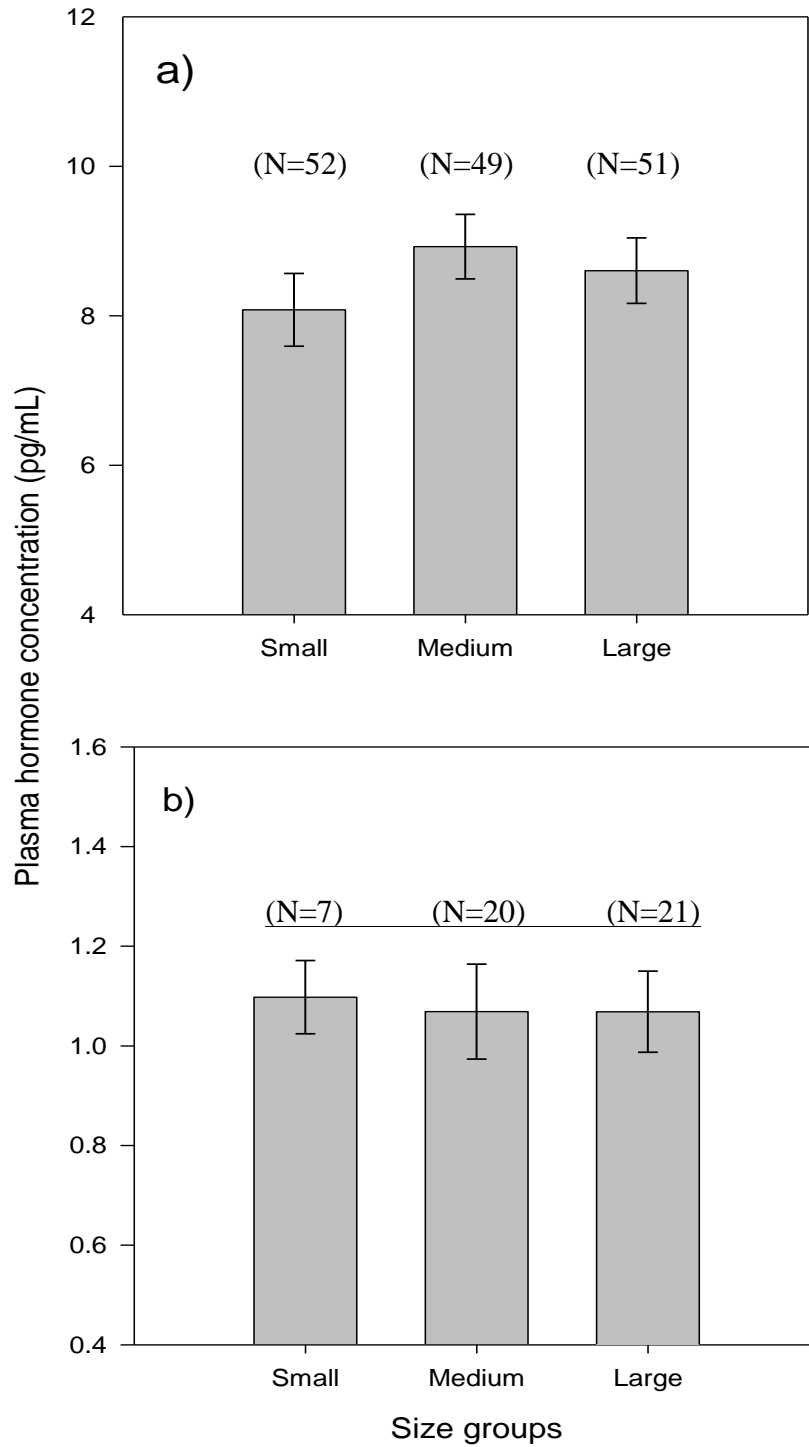

Figure 9: Mean plasma concentrations of T₃ (a) and T₄ (b) of all three size groups (samples pooled from all sample dates for each size group) with standard errors shown.

REFERENCES

- Allen, P. J., C. C. Barth, S. J. Peake, M. V Abrahams, and W. G. Anderson. 2009. Cohesive social behaviour shortens the stress response: the effects of conspecifics on the stress response in lake sturgeon *Acipenser fulvescens*. *Journal of Fish Biology* 74(1):90–104.
- Anderson, E. R., and W. C. Latta. 1984. Artificial propagation of lake sturgeon *Acipenser fulvescens* (Rafinesque), under hatchery conditions in Michigan. Master's thesis. University of Michigan. Ann Arbor, MI.
- Baker, D. W., S. J. Peake, and J. D. Kieffer. 2008. The effect of capture, handling, and tagging on hematological variables in wild adult lake sturgeon. *North American Journal of Fisheries Management* 28(1):296–300.
- Baker, E., and K. T. Scribner. 2015. Estimation of cohort-specific first year survival and evaluation of lake sturgeon stocking in Black Lake, Michigan. Grand Rapids, MI.
- Baker, E. A., and N. A. Auer. 2013. Habitat, Foods, and Feeding. Pages 59–78 in N. A. Auer and D. Dempsey, editors. *The Great Lake Sturgeon*. Michigan State University Press, East Lansing, MI.
- Barton, B. A. 2002. Stress in fishes: A diversity of responses with particular reference to changes in circulating corticosteroids. *Integrative and Comparative Biology* 42(3):517–525.

- Barton, B. A., and G. K. Iwama. 1991. Physiological changes in fish from stress in aquaculture with emphasis on the response and effects of corticosteroids. *Annual Review of Fish Diseases* 1:3–26.
- Bauman, J. M., B. M. Woodward, E. A. Baker, T. L. Marsh, and K. T. Scribner. 2016. Effects of family, feeding frequency, and alternate food type on body size and survival of hatchery-produced and wild-caught lake sturgeon larvae. *North American Journal of Aquaculture* 78(2):136–144.
- Belanger, J. J. Son, K. Laugero, G. Moberg, S. Doroshov, S. Lankford, and J. Cech. 2001. Effects of short-term management stress and ACTH injections on plasma cortisol levels in cultured white sturgeon, *Acipenser transmontanus*. *Aquaculture* 203(1):165–176.
- Bemis, W. E., and B. Kynard. 1994. Sturgeon rivers: an introduction to acipenseriform biogeography and life history. *Environmental Biology of Fishes* 48(1–4):167–183.
- Carey, R. A. 2005. *The Philosopher Fish*. 1st ed. Counterpoint, New York, NY.
- Caroffino, D. C., T. M. Sutton, R. F. Elliott, and M. C. Donofrio. 2010. Predation on early life stages of lake sturgeon in the Peshtigo River, Wisconsin. *Transactions of the American Fisheries Society* 139(6):1846–1856.
- Chebanov, M., and E. V. Galich. 2013. *Sturgeon Hatchery Manual*. United Nations, 978-92-5-106823-6, Krasnodar, Russia.

- Chrousos, G. P. 1998. Stressors, stress, and neuroendocrine integration of the adaptive response. The 1997 Hans Selye Memorial Lecture. Pages 311–335. Annals of the New York Academy of Sciences.
- Conte, F. S., S. I. Doroshov, P. B. Lutes, and E. M. Strange. 1988. Hatchery Manual for the White Sturgeon (*Acipenser transmontanus* Richardson): With Application to Other North American Acipenseridae. UCANR Publications, Oakland, CA.
- Dempsey, D. 2013. Sturgeon: The Great Lakes Buffalo. Pages 1–7 in N. A. Auer and D. Dempsey, editors. The Great Lake Sturgeon. Michigan State University Press, East Lansing, MI.
- Deng, D.-F., S. Koshio, S. Yokoyama, S. C. Bai, Q. Shao, Y. Cui, and S. S. . Hung. 2003. Effects of feeding rate on growth performance of white sturgeon (*Acipenser transmontanus*) larvae. *Aquaculture* 217(1):589–598.
- Eales, J. G., and S. B. Brown. 1993. Measurement and regulation of thyroidal status in teleost fish. *Reviews in Fish Biology and Fisheries* 3(4):299–347.
- Van Eenennaam, A. L., J. P. Van Eenennaam, J. F. Medrano, and S. I. Doroshov. 1999. Evidence of female heterogametic genetic sex determination in white sturgeon. *Journal of Heredity* 90:231–233.
- Fajfer, S., L. Meyers, G. Willman, T. Carpenter, and M. J. Hansen. 1999. Growth of juvenile lake sturgeon reared in tanks at three densities. *North American Journal of Aquaculture* 61(4):331–335.

- Fonds, M., R. Cronie, A. D. Vethaak, and P. Van Der Puyl. 1992. Metabolism, food consumption and growth of plaice (*Pleuronectes platessa*) and flounder (*Platichthys flesus*) in relation to fish size and temperature. *Netherlands Journal of Sea Research* 29(1–3):127–143.
- Gamperl, A. K., M. M. Vijayan, and R. G. Boutilier. 1994. Experimental control of stress hormone levels in fishes: techniques and applications. *Reviews in Fish Biology and Fisheries* 4(2):215–255.
- Gesner, J., M. Chebanov, and J. Freyhof. 2014. *Huso huso* (Beluga, European Sturgeon, Giant Sturgeon, Great Sturgeon). International Union for Conservation of Nature. <http://www.iucnredlist.org/details/10269/0>. (April 2015).
- Holtgren, J. M., S. A. Ogren, A. J. Paquet, and S. Fajfer. 2007. Design of a portable streamside rearing facility for lake sturgeon. *North American Journal of Aquaculture* 69(4):317–323.
- Hui, X., X. Zhu, X. T. Shi, X. B. Lu, D. Z. Zhang, J. Rao, and J. L. Jian. 2011. Compensatory growth and body composition in juvenile Chinese sturgeon *Acipenser sinensis* following temporary food deprivation. *Journal of Applied Ichthyology* 27(2):554–557.
- Johnsson, J. I., and T. Bohlin. 2006. The cost of catching up: increased winter mortality following structural growth compensation in the wild. *Proceedings of the Royal Society B: Biological Sciences* 273(1591):1281–6. The Royal Society.

- Khoroshko, P. N., and A. D. Vlasenko. 1970. Artificial spawning grounds of sturgeon. *Journal of Ichthyology* 10(3):286–292.
- Krieger, J., P. A. Fuerst, and T. M. Cavender. 2000. Phylogenetic relationships of the North American sturgeons (Order Acipenseriformes) based on mitochondrial DNA sequences. *Molecular Phylogenetics and Evolution* 16(1):64–72.
- Li, D., Z. Liu, and C. Xie. 2012. Effect of stocking density on growth and serum concentrations of thyroid hormones and cortisol in Amur sturgeon, *Acipenser schrenckii*. *Fish physiology and biochemistry* 38(2):511–20.
- Liu, W., Q. W. Wei, H. Wen, M. Jiang, F. Wu, and Y. Shi. 2011. Compensatory growth in juvenile Chinese sturgeon (*Acipenser sinensis*): effects of starvation and subsequent feeding on growth and body composition. *Journal of Applied Ichthyology* 27(2):749–754.
- Morshedi, V., P. Kochanian, M. Bahmani, M. A. Yazdani-Sadati, H. R. Pourali, G. Ashouri, H. Pasha-Zanoosi, and M. Azodi. 2013. Compensatory growth in sub-yearling Siberian sturgeon, *Acipenser baerii* Brandt, 1869: Effects of starvation and refeeding on growth, feed utilization and body composition. *Journal of Applied Ichthyology* 29(5):978–983.
- Nandi, J. B.-E. 1962. *The Structure of the Interrenal Gland in Teleost Fishes*. University of California Press, Berkley.
- Nesov, L. A., P. V. Fedorov, and N. I. Udovichenko. 1990. Jurassic, Cretaceous and

Palaeogene vertebrates of north-eastern Fergana and their significance in the
precising of age of sediments and palaeoenvironments. 2. Late Cretaceous and
Palaeogene. Descriptions of new forms of Jurassic vertebrates. Vestnik
Leningradskogo Universiteta:8–18.

Nicieza, A. G., and N. B. Metcalfe. 1997. Growth compensation in juvenile Atlantic
salmon: Responses to depressed temperature and food availability. *Ecology*
78(8):2385–2400.

Paragamian, V. L., G. Kruse, and V. Wakkinen. 2001. Spawning habitat of Kootenai
River white sturgeon, post-Libby Dam. *North American Journal of Fisheries
Management* 21(1):22–23.

St. Pierre, R. & Runstrom, A. (US. Fish. and Wildlife Service). 2014. *Acipenser
fulvescens* (Lake Sturgeon). International Union for the Conservation of Nature.
<http://www.iucnredlist.org/details/223/0>. (September 2014).

Plohman, J. C., T. A. Dick, and J. G. Eales. 2002. Thyroid of Lake Sturgeon, *Acipenser
fulvescens*. *General and Comparative Endocrinology* 125(1):47–55.

Post, H. 1890. The sturgeon; some experiments in hatching. *Transactions of the
American Fisheries Society* 19(1):36–40.

Power, D., L. Llewellyn, M. Faustino, M. Nowell, B.T. Björnsson, I. Einarsdottir, A. V.
Canario, and G. Sweeney. 2001. Thyroid hormones in growth and development of
fish. *Comparative Biochemistry and Physiology Part C: Toxicology &*

- Pharmacology 130(4):447–459.
- Refetoff, S. 1979. Thyroid Hormone Transport. *Endocrinology* 1:347–356.
- Reid, S. G., N. J. Bernier, and S. F. Perry. 1998. The adrenergic stress response in fish: control of catecholamine storage and release. *Comparative Biochemistry and Physiology Part C: Pharmacology, Toxicology and Endocrinology* 120(1):1–27.
- Russell, N. R., and R. J. Wootton. 1992. Appetite and growth compensation in the European minnow, *Phoxinus phoxinus* (Cyprinidae), following short periods of food restriction. *Environmental Biology of Fishes* 34(3):277–285.
- Szczepkowski, M., B. Szczepkowska, and I. Piotrowska. 2011. Impact of higher stocking density of juvenile Atlantic sturgeon, *Acipenser oxyrinchus* Mitchill, on fish growth, oxygen consumption, and ammonia excretion. *Archives of Polish Fisheries* 19(2):59–67.
- Threader, R. W., R. J. Pope, and P. R. H. Schaap. 1998. Development of a habitat suitability index model for lake sturgeon (*Acipenser fulvescens*). Toronto, Ontario.
- United States Fish and Wildlife Service. 2016. Lake Sturgeon Biology and Population History in the Great Lakes. U.S. Fish and Wildlife Service.
<https://www.fws.gov/midwest/sturgeon/biology.htm>. (August 2016)
- Welsh, A. 2013. Recognizing the Genetic Population Structure of Lake Sturgeon Stocks. Pages 9–92 in N. A. Auer and D. Dempsey, editors. *The Great Lake Sturgeon*.

Michigan State University Press, East Lansing, MI.

Williot, P., T. Rouault, M. Pelard, D. Mercier, M. LePage, B. Davail-Cuisset, F.

Kirschbaum, and A. Ludwig. 2007. Building a broodstock of the critically endangered sturgeon *Acipenser sturio*: Problems and observations associated with the adaptation of wild-caught fish to hatchery conditions. *Cybium* 31(1):3–11.

Wu, Y., and R. J. Koenig. 2000. Gene regulation by thyroid hormone. *Trends in Endocrinology and Metabolism* 11(6):207–211.

Yarmohammadi, M., A. Shabani, M. Pourkasemi, H. Soltanloo, M. R. Imanpour, S.

Ramezanzpour, C. Smith-Keune, and D. R. Jerry. 2013. Effects of starvation and re-feeding on compensatory growth performance, plasma metabolites and IGF-I gene expression of Persian sturgeon (*Acipenser persicus*, Borodin 1897). *Iranian Journal of Fisheries Science* 12(2):465–483.

Yen, P. M., and W. W. Chin. 1994. New advances in understanding the molecular mechanisms of thyroid hormone action. *Trends in Endocrinology & Metabolism* 5(2):65–72.

APPENDIX A: IACUC APPROVAL

**Application to Use Vertebrate Animals
in Research, Testing or Instruction**



Project Title (If using external funds, enter the title used on the grant application): Bimodal size distribution and growth compensation in hatchery-raised *Acipenser fulvescens*.

General Instructions

Please check the [IACUC website](#) to ensure you are using the current version of the form. All parts of this form *must be submitted electronically* to the Institutional Animal Care and Use Committee (email: IACUC@nmu.edu) and the relevant Department Head or other departmental designee. Review of this application will commence upon receiving the electronic application, but the project may not begin until all required approval signatures are obtained via Right Signature. Please contact the IACUC chair (email: IACUCChr@nmu.edu) if you have any questions.

Shaded area for IACUC use only.

Application Number: 256 Date
Application Received: 2/1/2015
Approved on: 4/28/2015
Denied on:

Review Dates:

Designated Member Review of applications (appropriate for USDA Use Categories B and C) will be completed within two weeks after receipt of the electronic application.

Full Committee Review of applications will take place on the last Friday of every month. **Applications for Full Committee Review must be electronically received by the first Friday of the month.** Full Committee Review is required for applications that fall under USDA Use Categories D and E. Applications that fall under USDA Use Categories B and C will receive Full Committee Review if requested by an IACUC member. Detailed procedures on the IACUC review processes are located at the [IACUC website](#).

I. Principal Investigator (Must be a faculty member or Department Head): Jill Leonard

Co- Investigator: Joseph Susco

Department: Biology

Phone number: 906-227-1619

II. Funding Sources/Course Information and Dates

If the proposed work is for a course, please include the number of the course and title of the course

Funding Sources (External & Internal, if applicable): Internal (Faculty Grant, Excellence in Ed)

Additional Funding Pending (click on the correct box)? Yes No

Project/Course Start Date: 4/1/15

End Date (three year maximum): December 31, 2016

This application is (check one) New Modification of an application currently approved by the Institutional Animal Care and Use Committee (a new protocol must be submitted after three years)

III. SPECIES, NUMBER OF ANIMALS, AND USE CATEGORY

In the table below, provide the Species to be used, the Number of each Species to be used, and indicate the USDA Use Category for the proposed procedures. A rationale must be provided below the table for using USDA Categories D and E procedures.

Species

Indicate the common name and scientific name of each animal to be studied. Use additional sheets if necessary. A rationale for choosing this species must be provided in Part V of this application.

Number of Animals

In the table below, indicate the maximum number of animals that will be used during the project period (up to 3 years) for each species.

USDA Use Category

For each species to be used, indicate the Use Category for the methods described in this proposal. A description of each USDA Category is given below. A rationale for Use Category D and E procedures must be provided.

USDA CATEGORY B: Animals that will be bred or purchased for breeding, but not used for experiments. This includes breeders, offspring that cannot be used because of improper genotype or gender and any other animals that will not participate in research studies.

USDA CATEGORY C: Animals used in research, experiments, or tests which involve no pain or distress or only momentary or slight pain or distress that **WOULD NOT REQUIRE** anesthetic, analgesic or tranquilizing agents (for example: s.c., i.m., i.p., or percutaneous i.v. injection, PIT tag insertion, a brief period of restraint, tissue harvesting after euthanasia).

USDA CATEGORY D: Animals used in research, experiments, or tests where appropriate anesthetic, analgesic, or tranquilizing agents are required to avoid pain or distress (e.g., major and minor surgery, tissue or organ collection *prior* to euthanasia, retro-orbital blood collection, prolonged restraint accompanied by tranquilizers or sedatives).

Animals used in research, experiments, or tests that *may* cause pain or distress, which cannot be treated with an anesthetic, analgesic or tranquilizer, but the agent or procedure producing the pain/distress is *immediately discontinued* or the animal is euthanized to prevent pain and/or suffering.

USDA CATEGORY E: Animals used in research, experiments, or tests involving pain or distress where the investigator is unable or unwilling to administer anesthetic, analgesic or tranquilizing agents (e.g., studies which allow endpoints that are painful or stressful, addictive drug withdrawals without treatment, pain research, noxious stimulation).

Common Name + (Scientific name)	Number of Animals	USDA Use Category
Lake Sturgeon (<i>Acipenser fulvescens</i>)	2400	C